

CZECHOSLOVAK BIPLANE FIGHTER 1:72 SCALE PLASTIC KIT



eduard

intro

ProfiPACK



The Avia B.534 was developed in 1934 as an extension of the B.34 fighter. In this incarnation, which was produced in small numbers for the Czechoslovak Air Force (the majority of which were attached to No.3 Fighter Regiment in Slovakia at the beginning of the Second World War), there were several engine/airframe combinations tried. The B.234 prototype served as the basis for the re-engined (Hispano Suiza 12 Ydrs for the original Avia R-29 radial) type that became the true B.534. This was the 1934 victor in a tender for a new standard fighter for the air force, and in June of that year, Avia received an order for an initial 34 aircraft. The orders accumulated to a total of 568 units, built in several production blocks.

Assessments of the aircraft are somewhat variable. At the time of its development, it was an aircraft that was technically sound and utilized progressive construction techniques, but by the time of the Munich Crisis, the technology was slowly but surely entering the realm of the obsolete. To top it off, the politics of the situation during the Crisis disallowed the chance of combat. The chance for combat missions to be flown didn't occur until a few years later, in 1941, in the services of the Slovak State, fighting for the side that had previously been the aggressor against which they were to stand. Slovak pilots flying the B.534 on the Eastern Front gained good results, and these can be viewed upon as being the climax of the career of the type. A year later, it was apparent that replacement by more modern types was necessary, and inevitable. Bulgarian attempts to combat Ploesti raiding B-24 Liberators with the B.534 was a failure, and the aging planes were not able to climb to the Liberator's operational altitudes. In Slovakia, as in Bulgaria, the type was destined for second line relegation.

Some of the remaining B.534s were destined for final operations within the Bulgarian Air Force in operations over Hungary in 1944, and with Slovakia during the several weeks long uprising against Germany (late August early November 1944). During the Slovak National Uprising, the type was used primarily in the ground attack role, and one did manage a kill to become what is the last aerial victory of a biplane in history. It should be noted that the kill in question was that of a Hungarian transport. The fact remains that the Slovak National Uprising did end up being the swansong of the Avia B.534. Certainly, it can be said that due to the era and climate of the service of this aircraft, and the length of service it was able to achieve, the Avia B.534 has become one of the most profound symbols of Czechoslovak aviation history, a very positive symbol.

Our model was influenced by these facts, and what the type means to us. We developed the kit with diligence and scrutiny, employing the most modern manufacturing technology at our disposal. In that sense, we have something in common with the original developers of the type all those years ago, and we hope that this fact will make our tribute to this aesthetically pleasing type longer lasting than the older big brother.

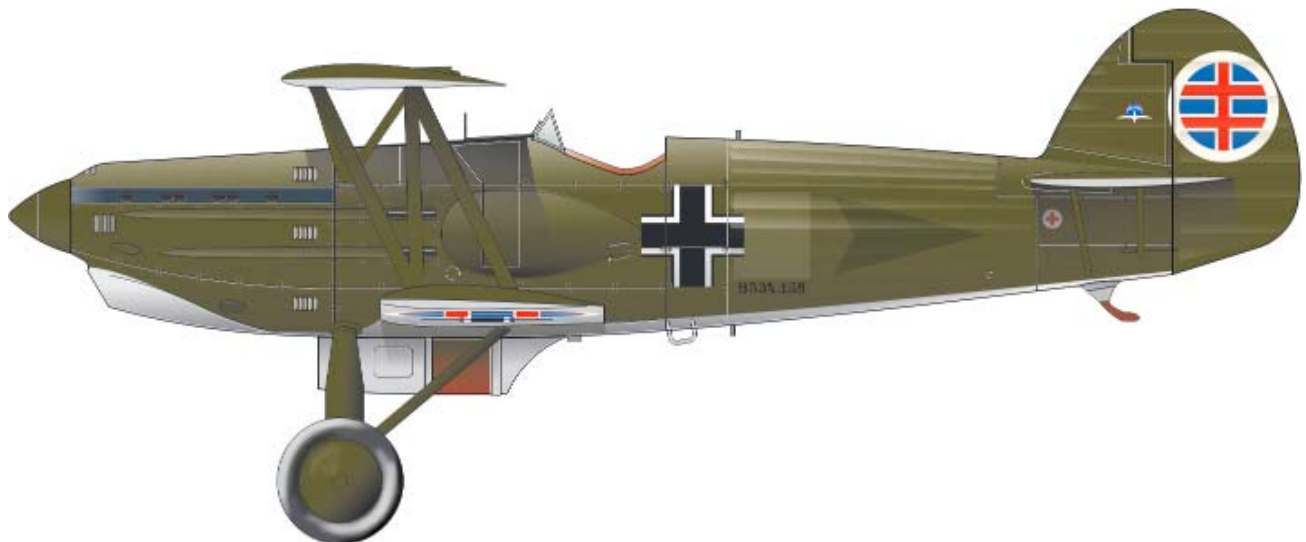



Carefully read instruction sheet before assembling. When you use glue or paint, do not use near open flame and use in well ventilated room. Keep out of reach of small children. Children must not be allowed to suck any part, or pull vinyl bag over the head.



Před započatím stavby si pečlivě prostudujte stavební návod. Při používání barev a lepidel pracujte v dobře větrané místnosti. Lepidla ani barvy nepoužívejte v blízkosti otevřeného ohně. Model není určen malým dětem, mohlo by dojít k požití drobných dílů.

INSTRUCTION SIGNS * INSTR. SYMBOLS * INSTRUKTION SINNBILDEN * SYMBOLES * 記号の説明



OPTIONAL
VOLBA



BEND
OHNOUT



OPEN HOLE
VYVRTAT OTVOR



SYMETRICAL ASSEMBLY
SYMETRICKÁ MONTÁŽ



NOTCH
ZÁREZ



REMOVE
ODŘÍZNOUT



APPLY EDUARD MASK
AND PAINT
POUŽIT EDUARDS MASK
NABARVIT

PARTS



DÍLY



TEILE



PIÈCES



部品

PLASTIC PARTS

A>

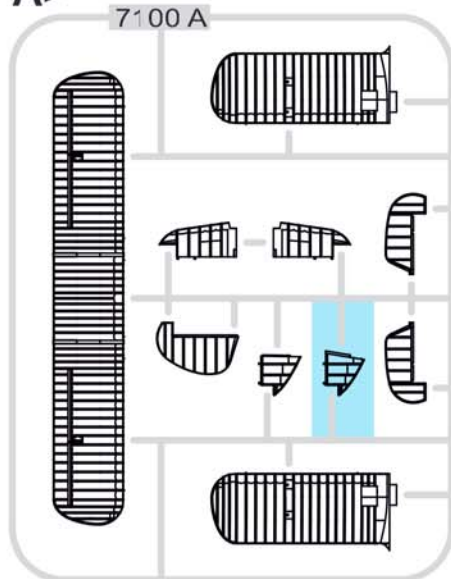

D>

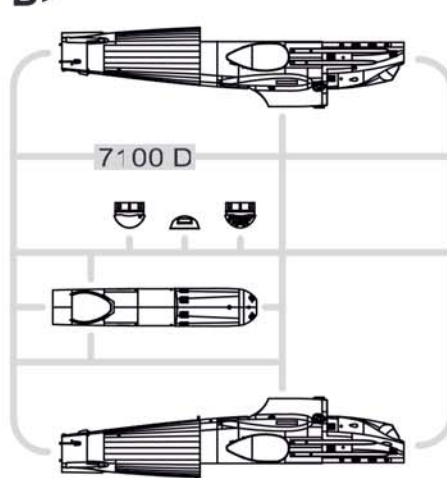
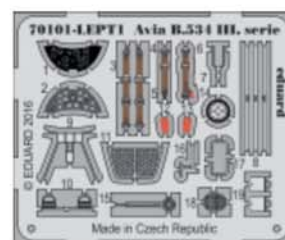
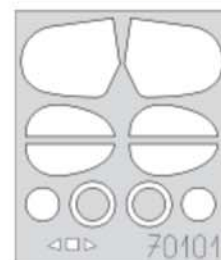
PE - PHOTO ETCHED
DETAIL PARTSeduard
MASK

E>

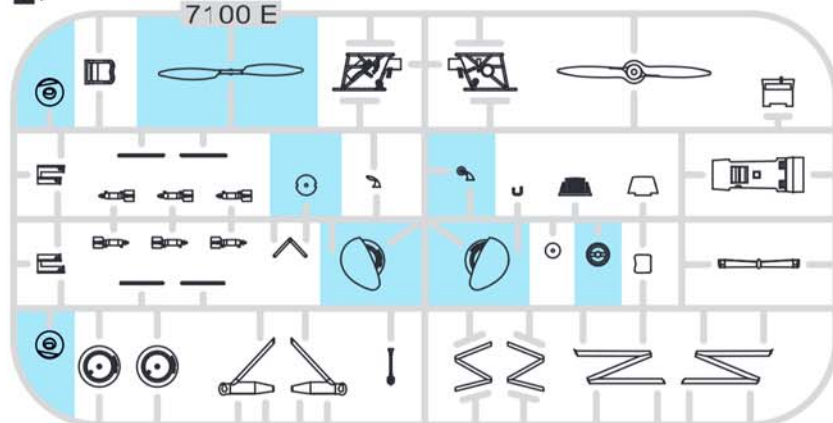

F>

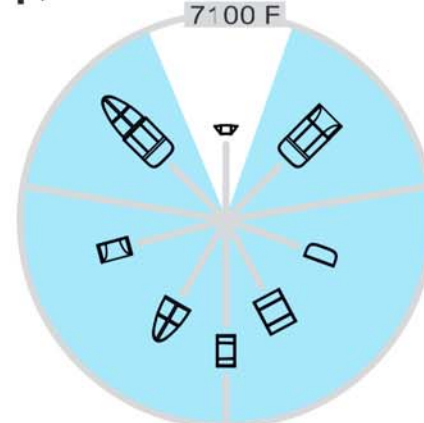

-Parts not for use -Teile werden nicht verwendet -Pièces à ne pas utiliser -Tyto díly nepoužívejte při stavbě - 使用しない部品

COLOURS



BARVY



FARBEN



PEINTURE



色

GSI Creos (GUNZE)		
AQUEOUS	Mr.COLOR	
H 4	C4	YELLOW
H 8	C8	SILVER
H 11	C62	FLAT WHITE
H 12	C33	FLAT BLACK
H 28	C78	METAL BLACK
H 37	C43	WOOD BROWN
H 47	C41	RED BROWN

AQUEOUS	Mr.COLOR	
H 64	C17	DARK GREEN RLM71
H 77	C137	TIRE BLACK
H 81	C55	KHAKI
	C111	CHARACTER FLESH
Mr.METAL COLOR		
	MC21d	DARK IRON
	MC21E	COPPER

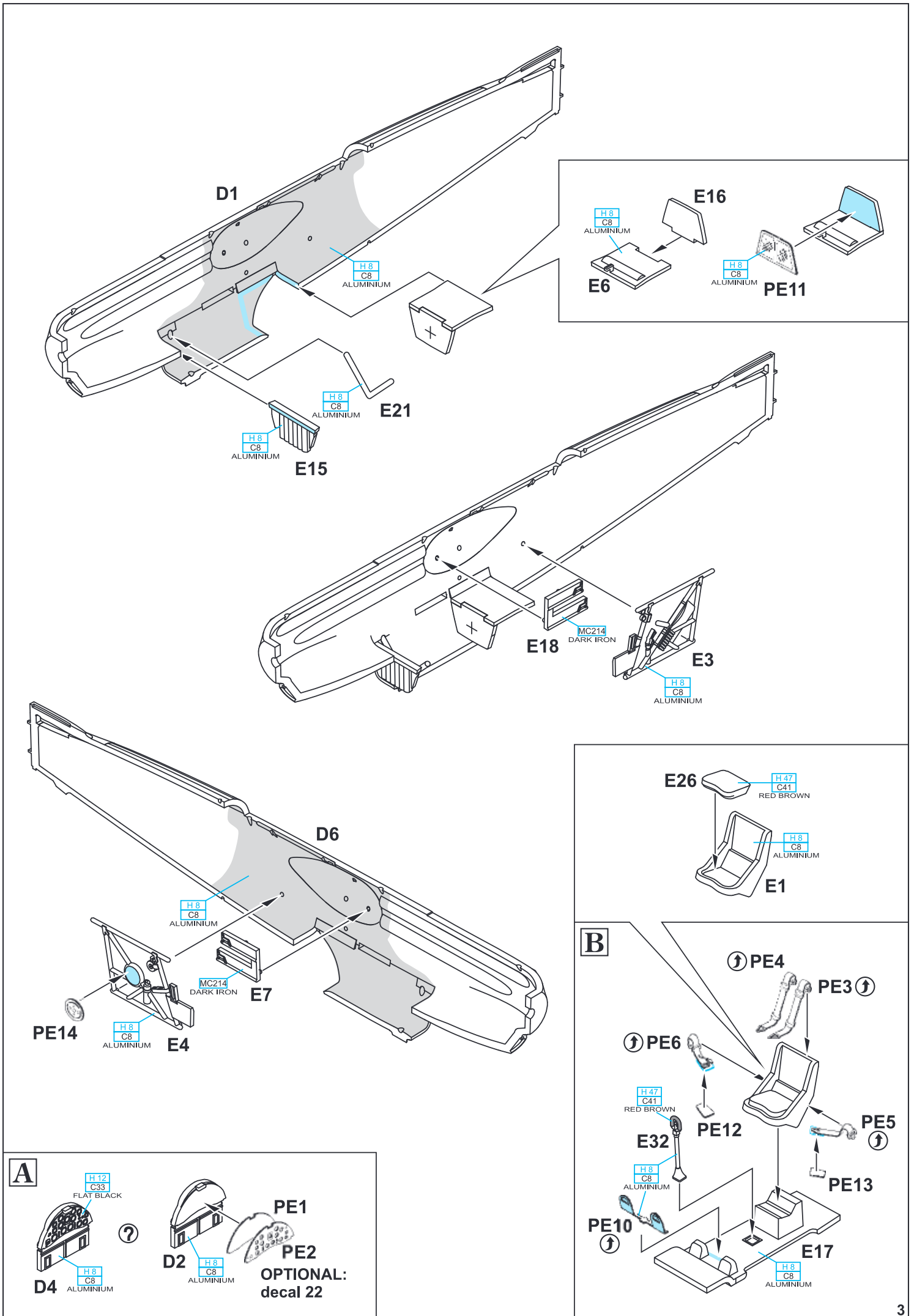

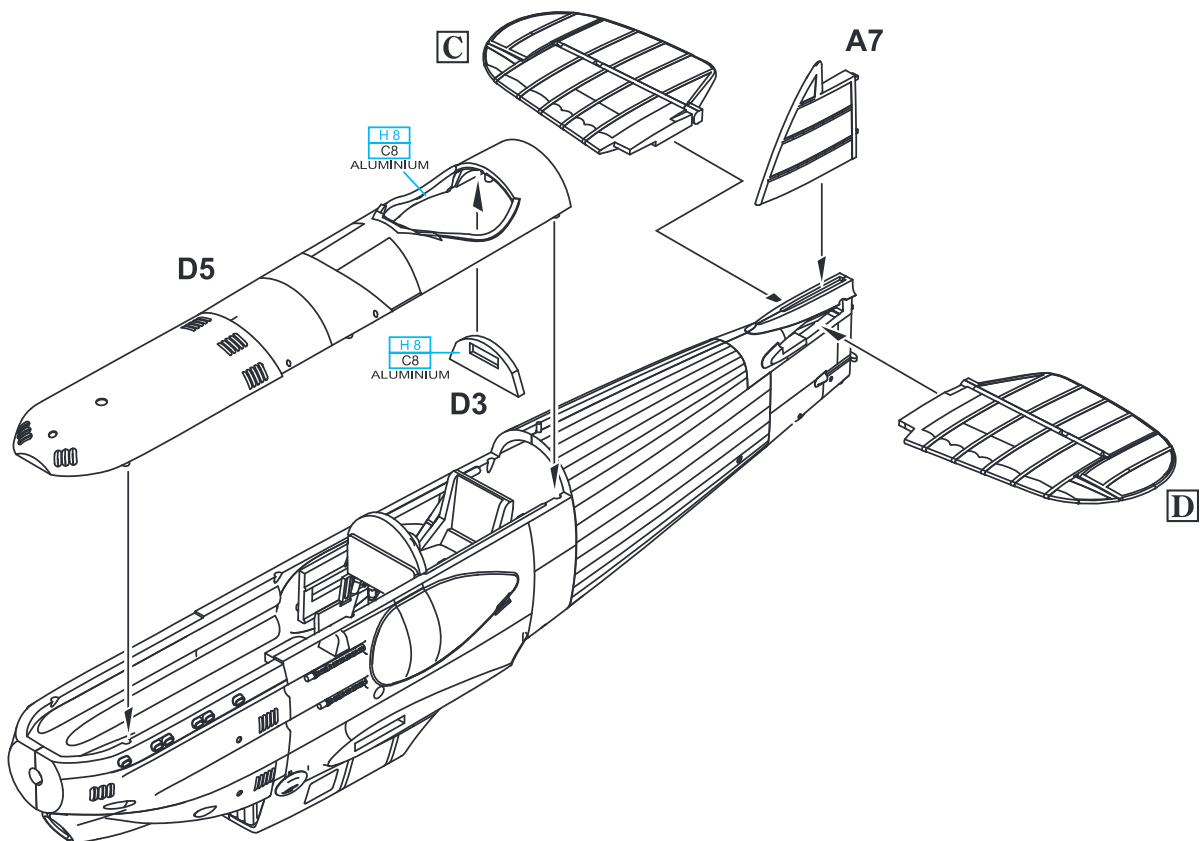
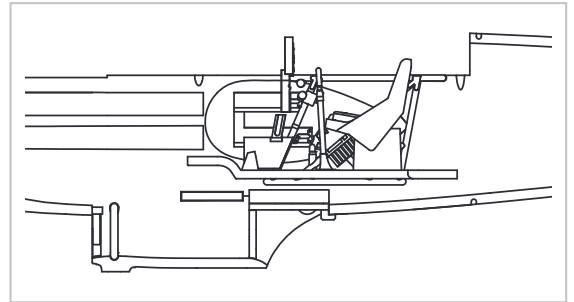
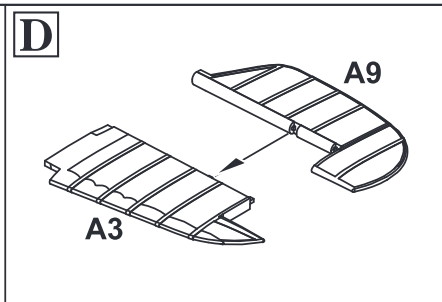
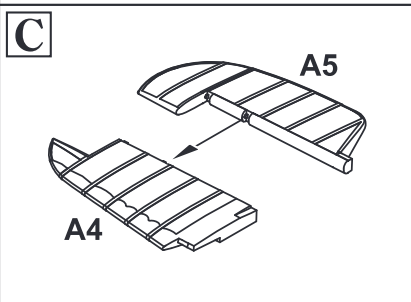
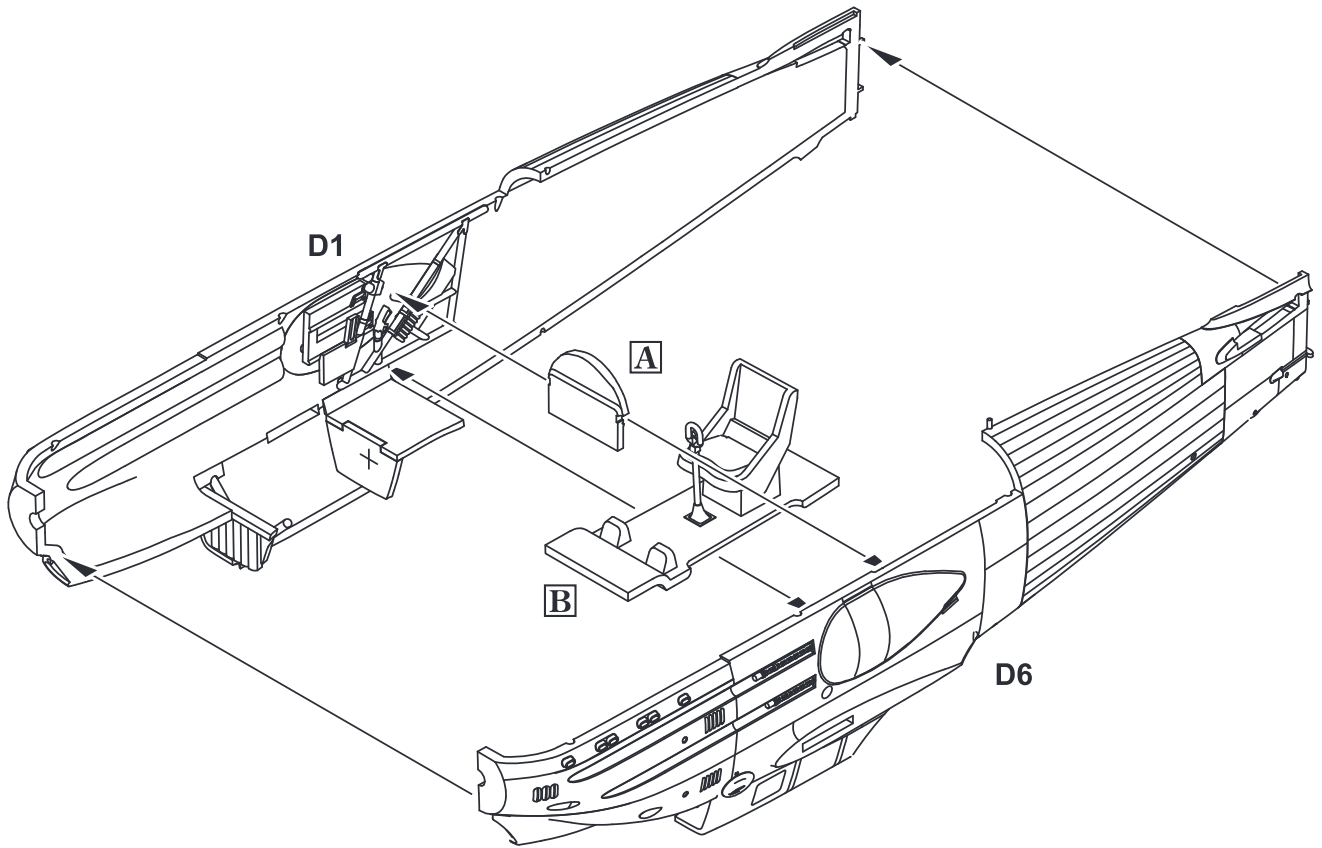

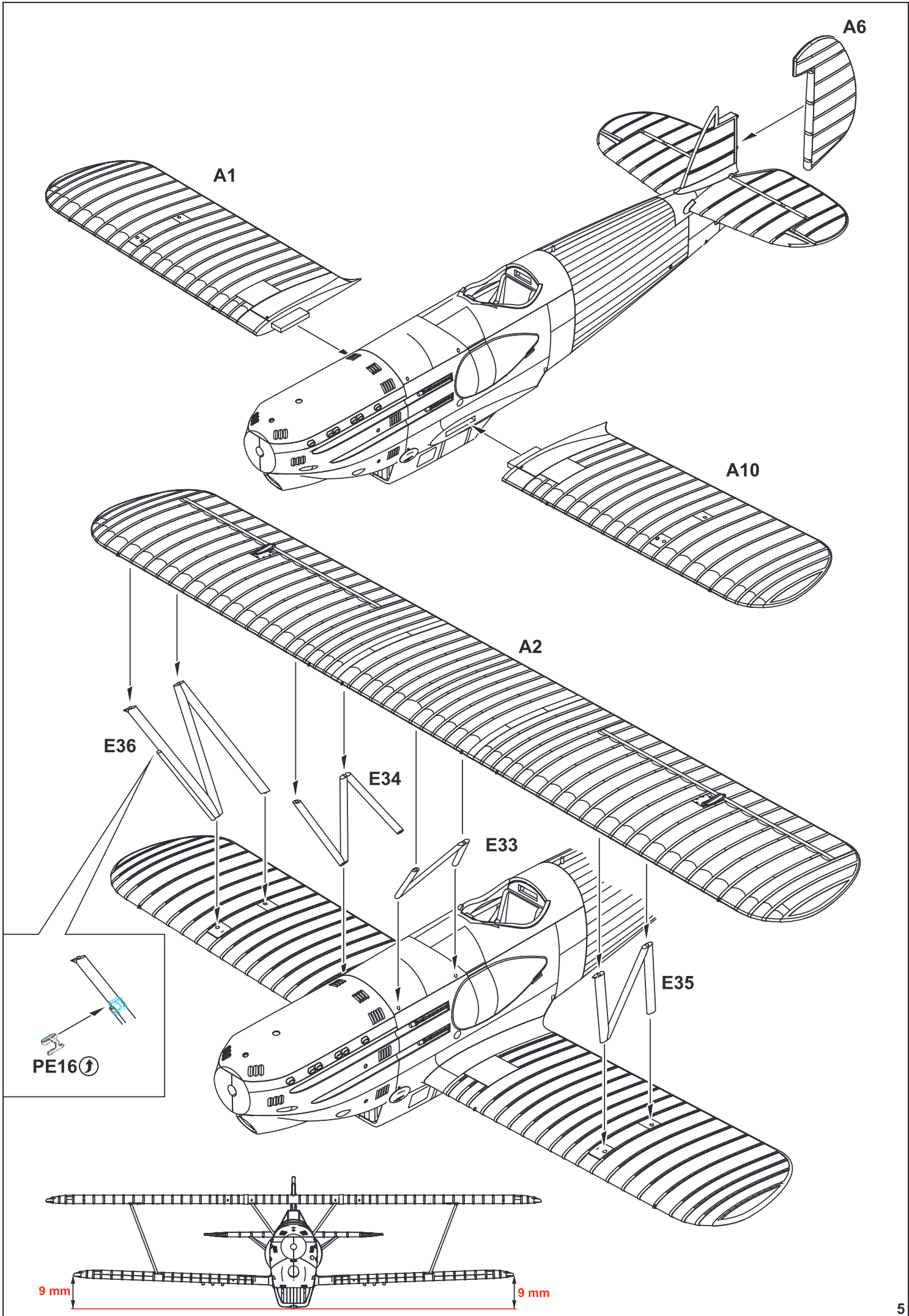

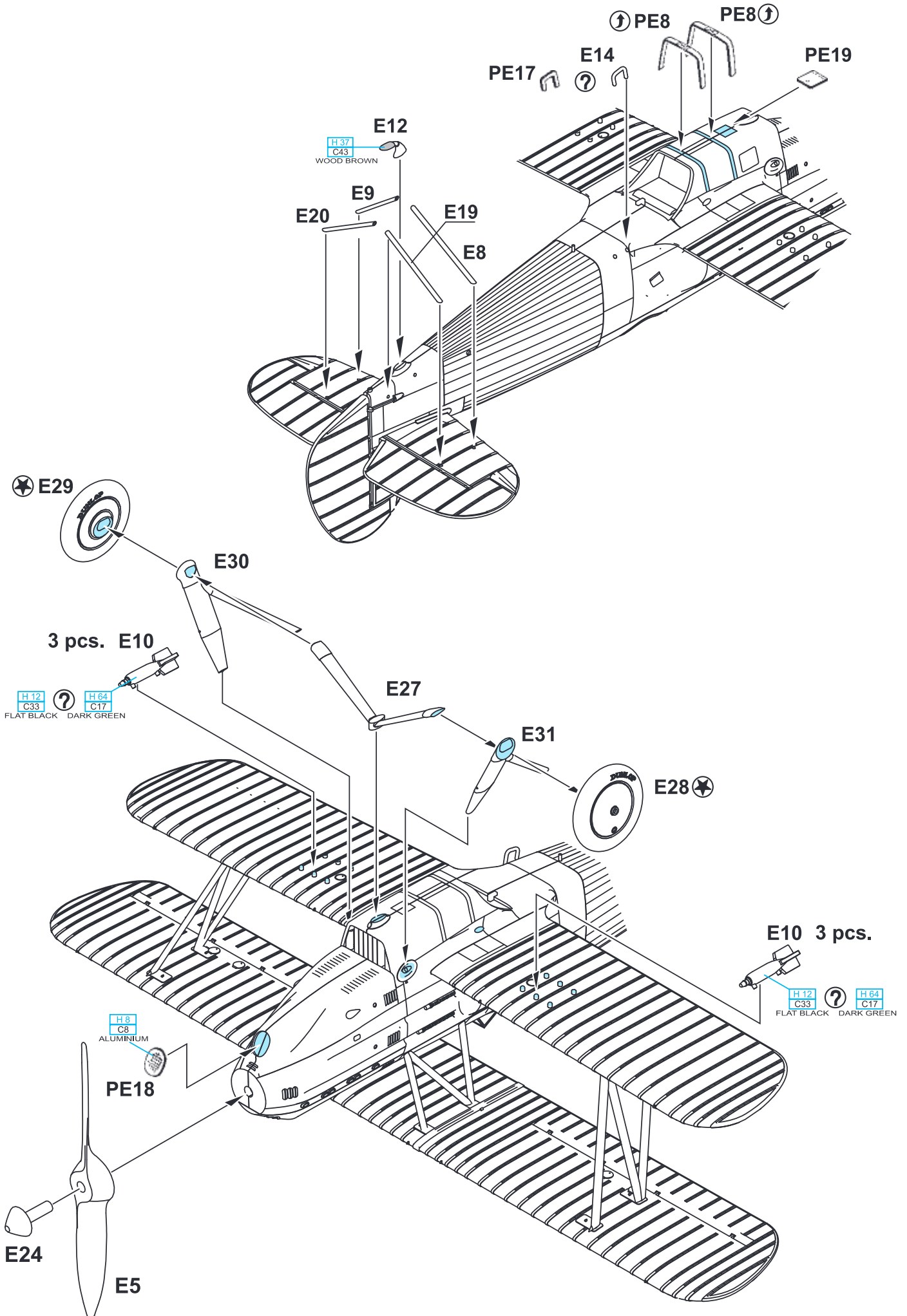

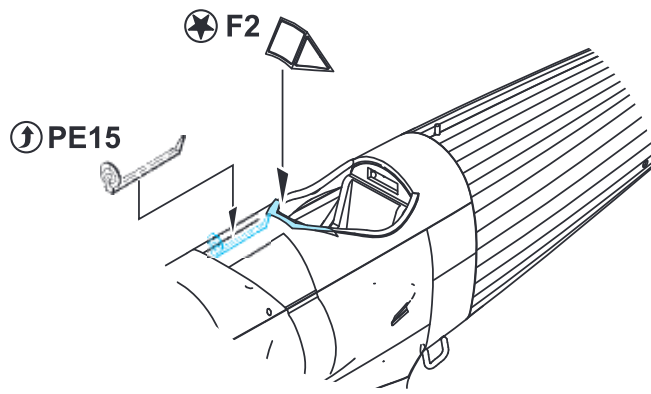

RIGGING DIAGRAM

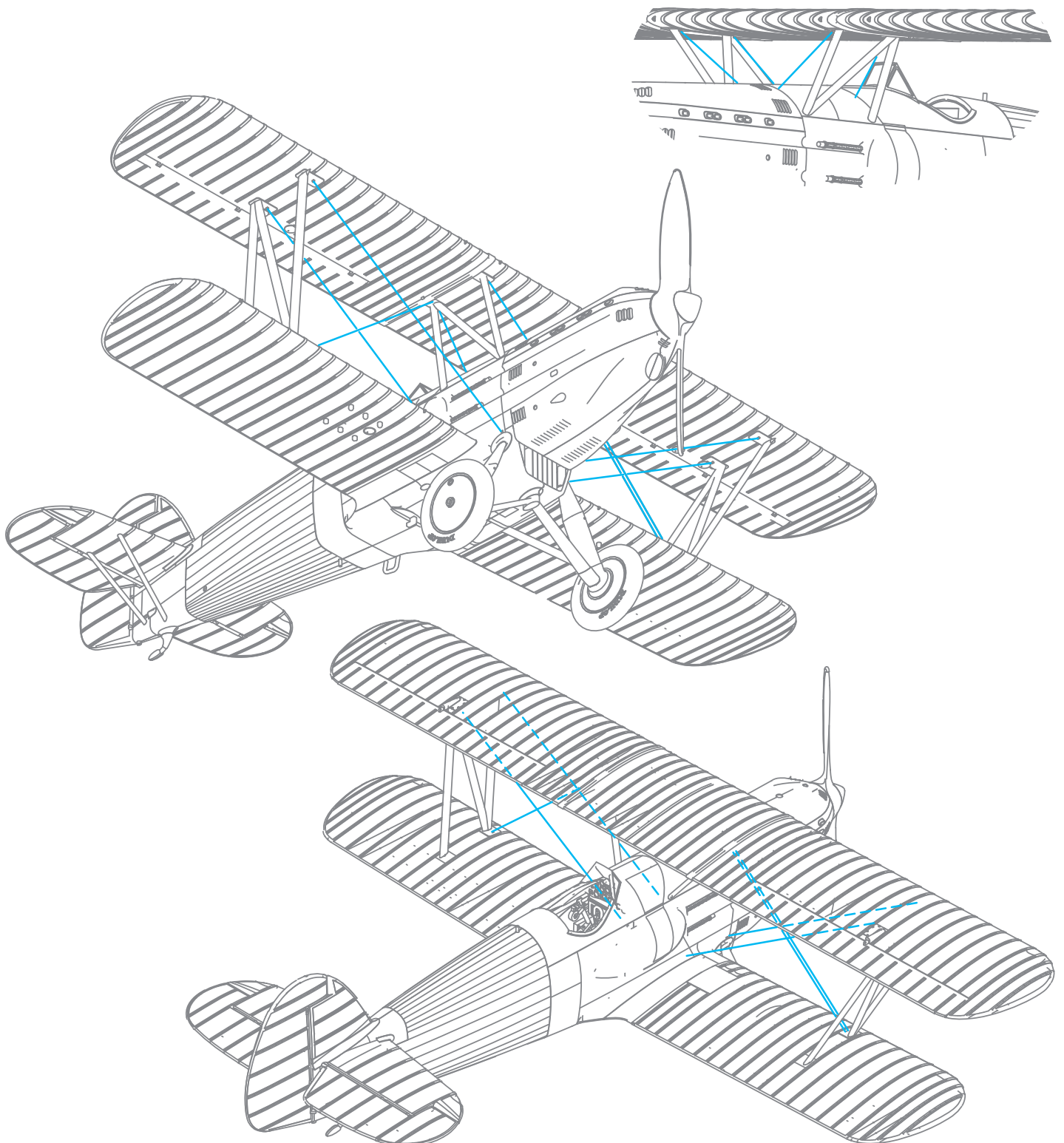

A B.534.158, Flown by Cpt. Josef Duda, No. 45 Flight, Air Regiment 3, Piešťany Air Base, February, 1938

Capt. Josef Duda crashed this aircraft near the village of Trnava (west of Hradec Kralove, Czechoslovakia) on February 8, 1938. The accident occurred on a flightpath through Piešťany – Brno – Olomouc – Hradec Králové – Olomouc – Piešťany.

ČESKOU VERZI TEXTU NALEZNETE NA
www.eduard.com/s/70101

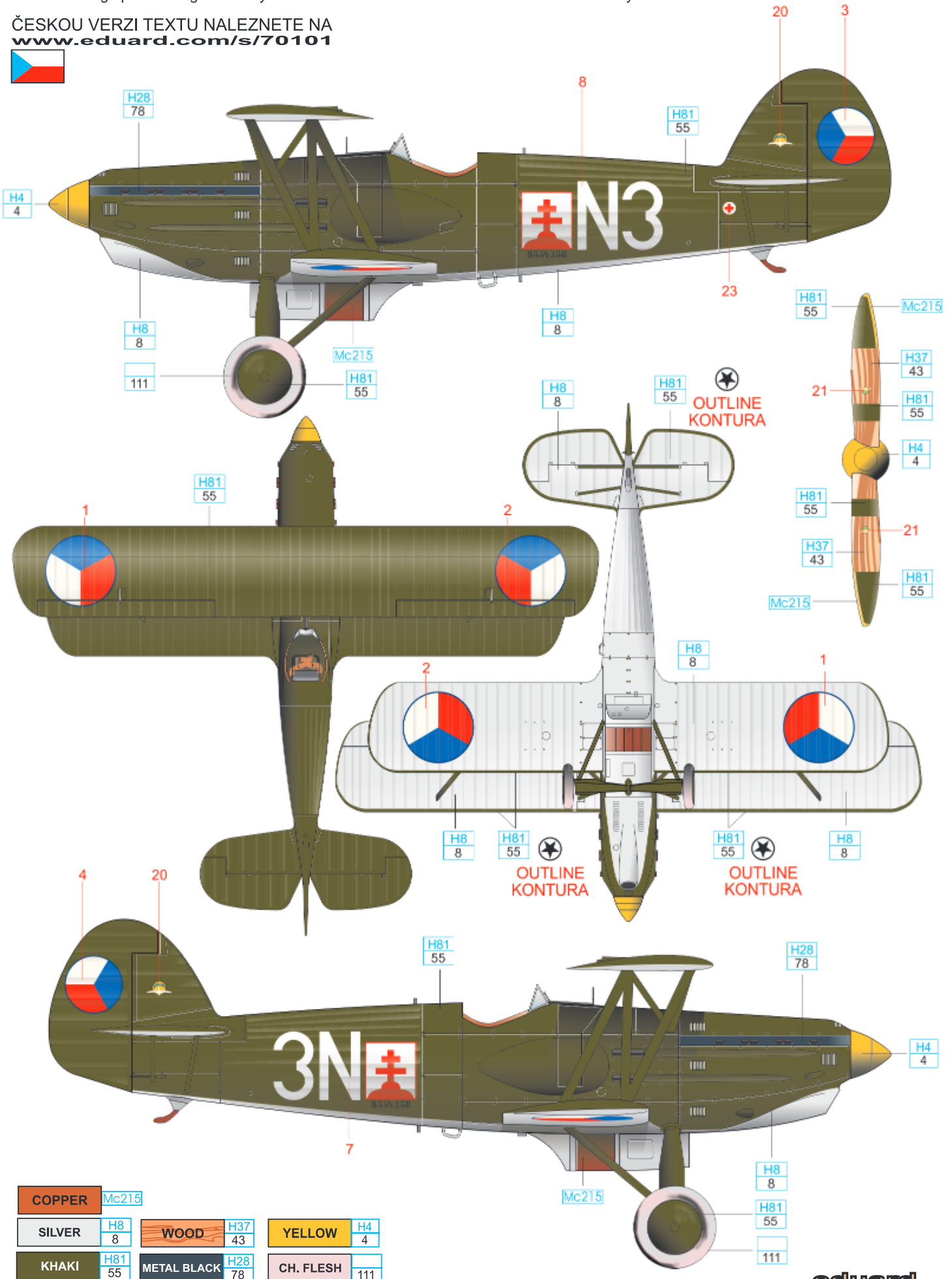

COPPER	Mc215	WOOD	H37 43	YELLOW	H4 4
SILVER	H8 8	METAL BLACK	H28 78	CH. FLESH	111
KHAKI	H81 55				

C B.534.158, Slovak Air Force, Piešťany Air Base, 1939

After the dissolution of Czechoslovakia, this B.534 was flown by the Slovak Air Force. Note the combination of German and Slovak national insignia.

ČESKOU VERZI TEXTU NALEZNETE NA
www.eduard.com/s/70101

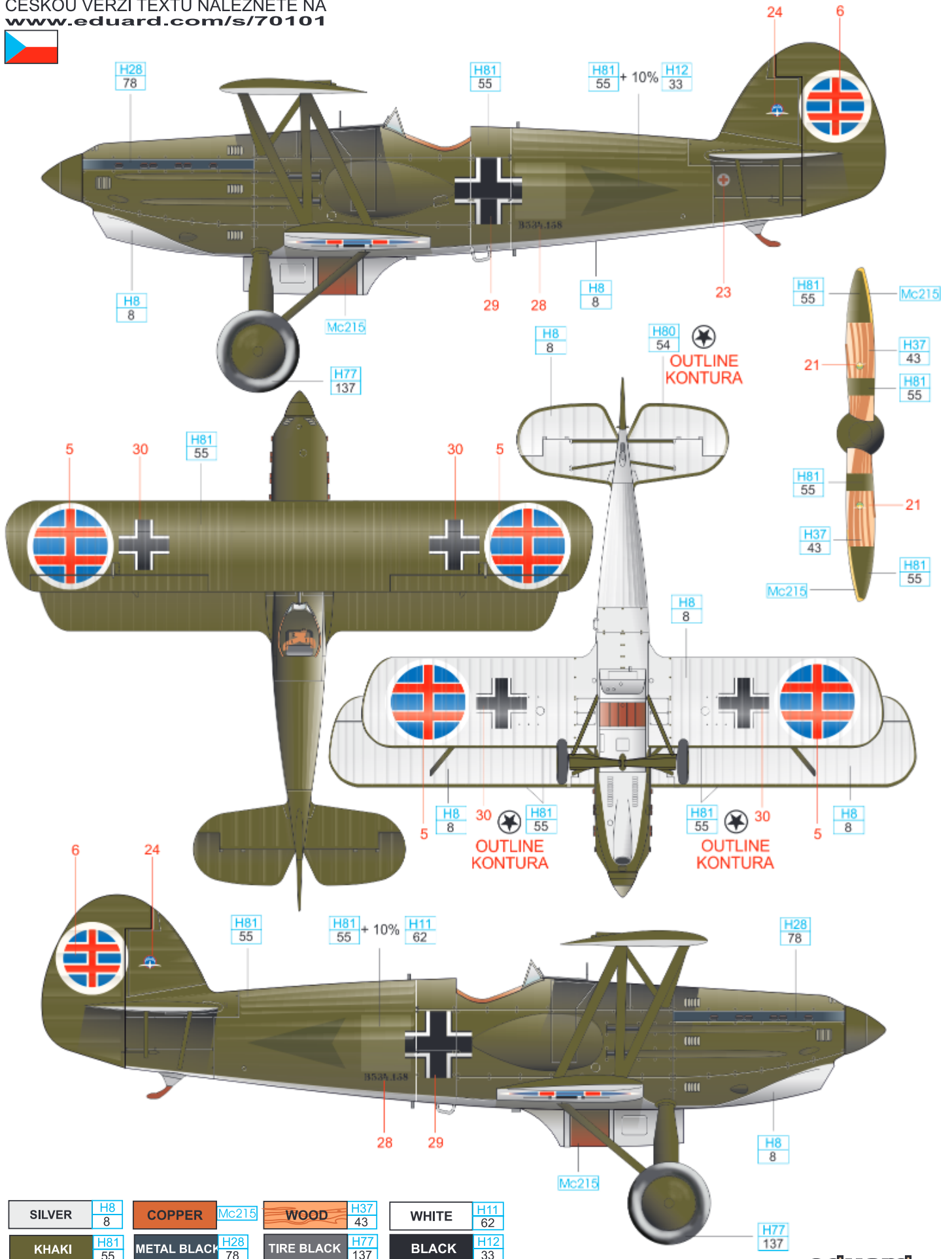

SILVER	H8 8	COPPER	Mc215	WOOD	H37 43	WHITE	H11 62
KHAKI	H81 55	METAL BLACK	H28 78	TIRE BLACK	H77 137	BLACK	H12 33

This aircraft was probably flown by one of the Luftwaffe flying schools, but unfortunately, the identity of the school is not known. It wore original Czechoslovak camouflage colours, white German stencils were drawn on the cowling and tail. The colour of the spinner is not fully confirmed.

ČESKOU VERZI TEXTU NALEZNETE NA
www.eduard.com/s/70101

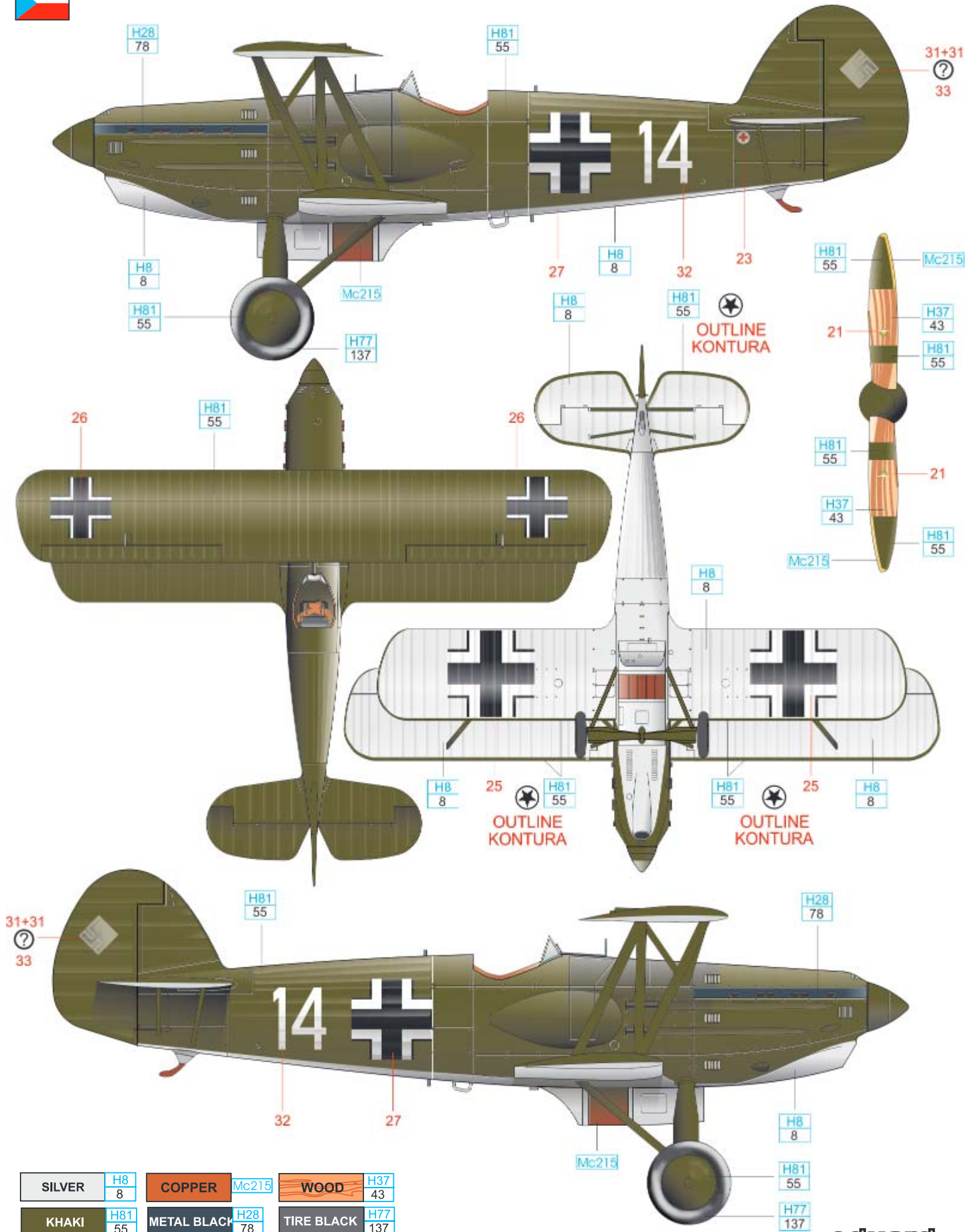

SILVER	H8 8	COPPER	Mc215	WOOD	H37 43
KHAKI	H81 55	METAL BLACK	H28 78	TIRE BLACK	H77 137

